



Compact Unscrambling System Model: NEHCP-36



NEHCP-36 compact unscrambler w/ optional ionized air rinser

The New England Machinery, Inc. NEHCP-36 is a compact unscrambling system. This model offers a compact, space saving footprint due to an integrated hopper elevator. The NEHCP-36 is designed for high efficiency and high output.

Versatility - The NEHCP-36 easily integrates into existing filling, capping and decorating equipment as well as other equipment in your packaging operations. The low profile design allows for easy container loading and operation and maintenance.

Dependability - This system offers an integrated bulk supply hopper elevator and orienting bowl to provide a steady supply of properly oriented containers to the line. The NEHCP-36 also offers easy access to all sub-assemblies for fast, efficient maintenance.

Speed - Depending on container size and configuration, this model can reach speeds up to 400 containers per minute.

NEHCP Snapshot:

- Completely enclosed/dust protection
- Tubular 304 stainless steel welded frame
- Aluminum and 304 stainless steel construction
- Clean, non-painted, non-marring surfaces
- Soft start and stop features
- Powder coated aluminum faceplate
- Integrated 15 cu.ft. hopper with vertical elevator
- Safety interlocks on all guarding doors
- Non-scuffing nylon faced padded transfer belts
- Linatex faced timing belts
- Jog switch w/ 10 foot cord
- Adjustable discharge height 36" \pm 2"
- High floor clearance
- Smoothed and polished welds
- Direct discharge to customer's constant speed, continuous motion conveyor
- Operations and maintenance manual
- Manual dump valve (release all vacuum or compressed air from the system)

New England Machinery, Inc.

Innovators In Container Handling Systems • • • • • • • • • •



NEHCP-36 Specifications

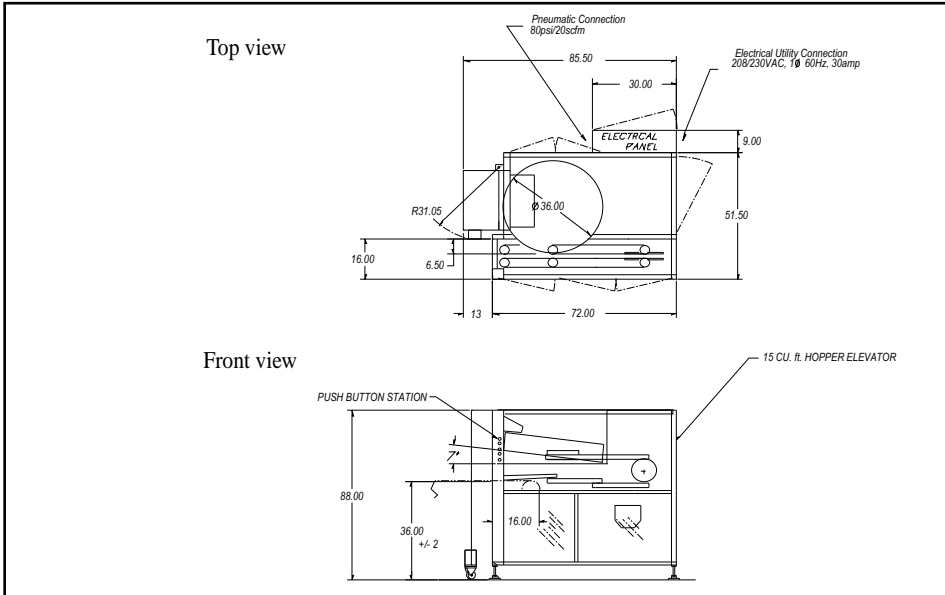

Non-scuffing nylon faced padded transfer belts



Optional ionized air rinsing



End view. Easy for loading bottles.

ELECTRICAL FEATURES

- NEMA-12 electrical
- 208/220V, single phase, 50/60Hz input requiring 30 amp service
- Backlog photo-eye w/automatic stop and restart
- Allen-Bradley® AC variable frequency drives
- Allen-Bradley® Micro Logix 1000 PLC

PNEUMATICS

- 5-10 cfm. @ 80 psi. clean, dry, oil-free compressed air



Optional Allen-Bradley® touch panel shown

Optional Equipment

- PLC upgrade
- Built-in ionized air rinsing
- Caster wheels
- Change from std. (36" +/-2") discharge height
- Digital container counter (cpm or cumulative)
- Extended range available
- Left-hand discharge
- Quick change feature
- Upgrade machine guarding to polycarbonate
- Roll-ramp discharge
- NEMA-4 electrical
- Supply hopper low level detection and indication
- Machine status light stack
- Allen-Bradley® HMI touch-screen
- Additional emergency stop button(s)
- Central cluster lubrication

NEHCP-36 Unscrambler can be configured to customer specification, upon request.

New England Machinery, Inc.

2820 62nd Ave East, Bradenton, FL 34203 U.S.A.

941/755-5550 Fax: 941/751-6281

www.neminc.com

E-mail: info@neminc.com

Changes in machine design or specifications are a result of continuous machine improvements and New England Machinery, Inc. reserves the right to change standard specifications without prior notice. The above illustration(s) and text are representative in scope only.

NEHCP-36 11/07