

# Rotary Beltless Unscrambler

## Model: NERBU



*NERBU Rotary Beltless Unscrambler with optional integrated pucking system*

The New England Machinery Model NERBU is a Rotary Beltless Unscrambler. This unscrambler offers a uniquely designed adjustable sorting bowl, adjustable container chute, and adjustable container transport stations. The bowl is designed without intrusive structures in the bowl to impede the container sorting process. The equipment is offered with optional automated changeover via touch screen menu selection.

This rotary turret style machine is designed with all FDA approved contact surfaces. It comes equipped with a 6' discharge exit conveyor.

### FEATURES:

- No change parts required
- Small machine footprint
- Low overall machine height
- Beltless unscrambling
- Optional ionized air rinsers in passive, evasive or invasive
- Fast, easy, tool-less changeover via hand dials or optional touch screen
- Fully adjustable bowl, chute, and container transport
- Handles container sizes from 1-1/8" to 5" dia. and 1-5/8" to 8" ht with small bottle option
- Designed for pharmaceutical applications



*Close-up of rotary beltless unscrambling area and optional integrated pucking system*

### NERBU Snapshot:

- Ideal for Pharmaceutical, Nutritional, Food, Beverage & Personal Care Products
- Fast and easy changeover with no change parts
- Fully adjustable bowl with no change parts
- Fully adjustable chute with no change parts
- Fully adjustable transport stations with no change parts
- Tubular 304 stainless steel welded frame
- Clean, non-painted, non-marring surfaces
- Safety interlocks on all guard doors
- Discharge exit conveyor
- Adjustable discharge height 36" +/- 2"
- High 6" floor clearance
- Smoothed and polished welds
- Discharge to customer's constant speed, continuous motion, non-stopping conveyor
- UL listed components

**New England Machinery, Inc.**

*Innovators In Container Handling Systems*



# NERBU Specifications

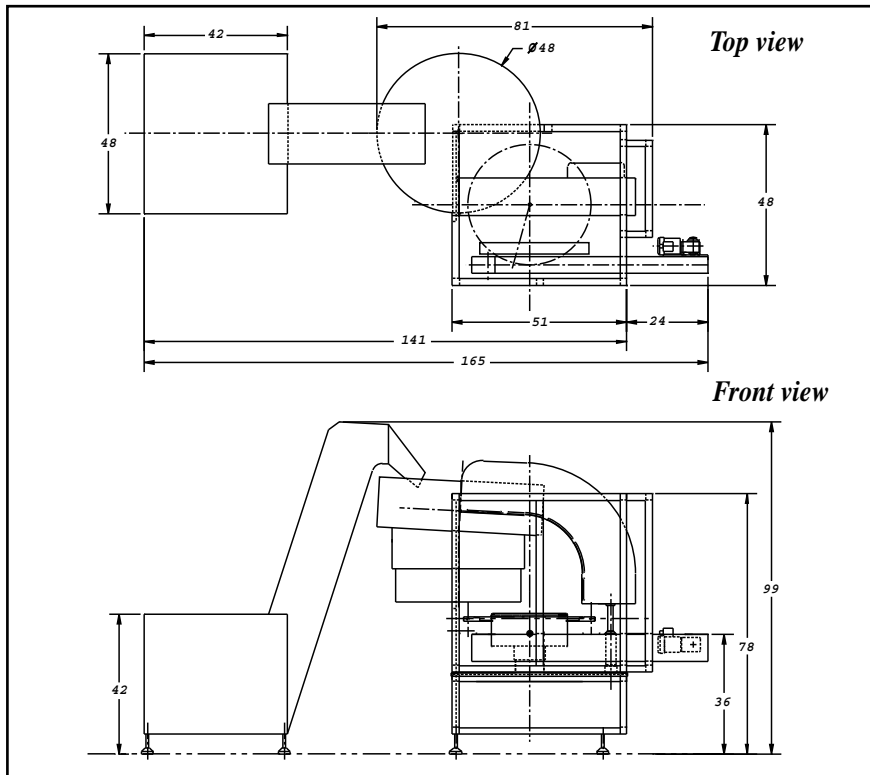

## BENEFITS

- Easy changeover
- No change parts
- Round, oval, rectangular and square container shapes and sizes from 30 ml to 1000 ml

## ELECTRICAL FEATURES

- NEMA-12 electrical
- 220 volt, 3 phase, 60Hz input requiring 30 amp service
- Backlog photo-eye w/automatic stop and restart
- Allen-Bradley® VFD Drives
- Allen-Bradley® PLC

## PNEUMATICS

- 5-10 cfm. @ 80 psi. clean, dry, oil-free compressed air

NERBU Unscrambler can be configured to any customer specification, upon request.

**New England Machinery, Inc.**

2820 62nd Ave East, Bradenton, FL 34203 U.S.A.

941/755-5550 Fax: 941/751-6281

www.neminc.com

E-mail: info@neminc.com

Changes in machine design or specifications are a result of continuous machine improvements and New England Machinery, Inc. reserves the right to change standard specifications without prior notice.

NERBU 09/06

## Optional Equipment

- Fully automatic changeovers
- Anodized aluminum
- Invasive, evasive or passive ionized air rinsers
- NEMA-4X (wash down)
- Transformer for different input voltages
- Change from standard discharge height 36" +/- 2"
- Left-hand discharge
- Industry standard light stack
- Bulk hopper low level detection sensor and lighted alarm indicator
- Larger bulk hopper capacities
- Larger sorting bowls
- Cluster central lubrication
- Digital container counter (bottles per minute)
- Heavy duty lockable caster wheels
- Additional emergency "E" stop(s)
- HMI (human machine interface)
- Spare parts kit
- Pucker